

Study of Reasonable Reinforcement Method for Underground Power Cable Tunnel in Soft Cohesive Soil Ground

Yoh NAKAJIMA, Masahiro OOTSUKA and Shigeru TANABE
Transmission Department, Tokyo Electric Power Company

ABSTRACT: Because deformation and crack development have been observed in ageing tunnels of Tokyo Electric Power Company, we analyzed the causes and investigated methods for reinforcing the tunnels. Through various investigation, it was determined that the tunnel deformation was caused by increases in the earth pressures acting on the tunnel due to long-term consolidation settlement resulting from the fall of the groundwater level in the ground and the inflow of groundwater into the tunnel. A series of study methods for predicting increases in additional long-term load, evaluating the residual strength of an existing tunnel, judging the necessity of reinforcement to resist additional loading, and determining the time and method of reinforcement was determined, and the reinforcement method was applied to a markedly deformed tunnel in soft cohesive soil ground.

KEYWORDS: tunnel deformation, consolidation settlement, additional long-term load

1. INTRODUCTION

Tokyo Electric Power Company supplies electric power to the Kanto region including Tokyo, Yokohama etc. In urban areas, since the 1960s, the installation of transmission lines in the under-road space has been carried out in coordination with urban planning, and many utility tunnels have been constructed to contain power cables. The total length of these power cable tunnels has reached about 480 km. Many of those tunnels are in a sound condition, but some of the tunnel structures in harsh environments have been variously deformed. It has been found that some of the old tunnels constructed in soft cohesive soil ground are greatly deformed to the extent of requiring reinforcement in order to keep the power transmission facilities functional.

The shape of the cross section of the tunnel is generally circular or rectangular.

The shape and dimensions of the tunnel inner section is decided based on the necessary space for accommodating power cables and facilities for lighting, draining, etc. and the necessary working and walking space. The inner diameters are about 2 to 7 m.

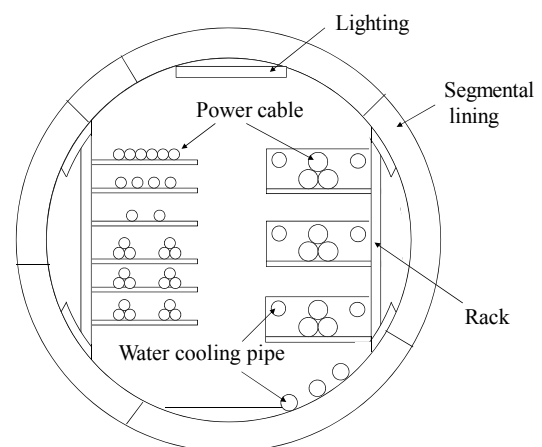

Figure 1 Typical cross section of a power cable tunnel

2. OVERVIEW OF UNDERGROUND POWER CABLE TUNNEL

The depths of the tunnels are about 2 to 50 m from the ground surface.

The tunnels are required to resist external forces such as earth pressure and water pressure, prevent inflow of underground water, and secure necessary inner space for the maintenance of power cable.

The tunnels are either steel or cast-in-place or precast reinforced concrete.

The tunnels can be classified by construction method into open cut tunnels, which are constructed by digging the ground surface, constructing a tunnel and covering the completed tunnel, and those constructed using the non-digging method, which involves excavating and constructing a tunnel underground. The mainly used non-digging method is the shield tunneling method, which involves thrusting a strong steel pipe called a shield into the ground, excavating the ground at the front end and assembling precast pieces called segments at the rear end.

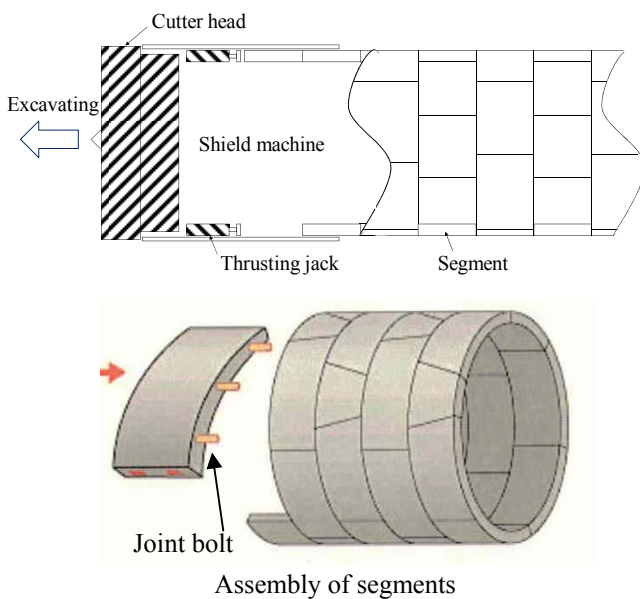

Figure 2 Shield tunneling method

3. MAINTENANCE OF TUNNEL

Tunnels are maintained so as to keep the performances for transmitting power throughout the service period by early detecting abnormality of

structures and taking appropriate measures. Tunnels are maintained according to the procedure shown in the manual we prepared. The procedure is shown in Figure 3.

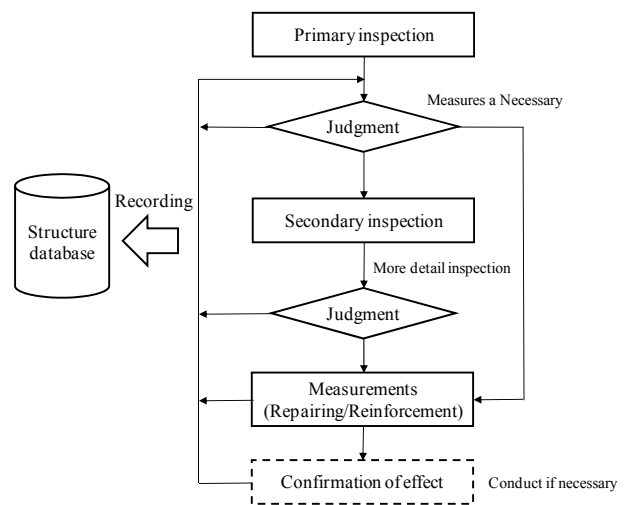

Figure 3 Maintenance flow of power cable tunnel

Primary inspection involves visual inspection and simple measurements for checking whether there is abnormality or not and the degree of the abnormality if there is any. Primary inspection is usually performed once every six years.

Secondary inspection involves collecting data needed for estimating the causes of abnormality, investigating the durability of the tunnel.

Repairing is performed aiming to prevent or control the abnormality from progressing further.

Reinforcement is performed when the strength of the tunnel is judged to be insufficient, aiming to restore or improve the strength.

The procedure and results of each step through to the finished measurements are recorded for future reference.

4. ABNORMALITY OF TUNNEL

Points prone to abnormalities and their mechanisms are shown in Table 1 for each kind of abnormality of existing tunnels. A tunnel at an abnormal state is shown in Figure 4.

Table 1 Abnormality of existing tunnel

Abnormality	Point	Causes and mechanisms
Cracks	Slab, Side wall	#Substandard construction #Insufficient member thickness and insufficient amount of steel #Changes in external forces (changes in earth cover, underground water level, etc.) #Changes in supporting conditions (uneven settlement, restraint of deformation, etc.)
Exfoliation and loss	Slab, Side wall	#Caused by cracks accompanying progress of corrosion #Caused by damages during construction #Caused by load exceeding the design load, such as during an earthquake
Grade difference	Joint of tunnel	#Caused by external forces such as uneven settlement
Leak of water including inflow of sediments	Point of cracks	#Infiltration of water and soil through point of cracks
	Grouting hole of segment	#Infiltration of water and soil through openings attributable to insufficient grouting
	Joint of segment	#Infiltration of water and soil through openings caused by loosening of joint bolt, etc. #Infiltration of water and soil by deterioration of sealing materials
	Joint of tunnel	#Infiltration of water and soil due to poor waterproofing during construction
Corrosion of reinforcing steel	Point of leakage, Joint of segment	#Infiltration of water and soil through point of cracks #Infiltration of water and soil due to poor waterproofing during construction



Figure 4 Example of tunnel at abnormal state

5. ABNORMALITIES OF TUNNELS IN SOFT COHESIVE SOIL GROUND

Some tunnels constructed in soft cohesive soil ground were found to suffer common abnormalities. The abnormalities and the peripheral conditions are summarized below:

- The tunnels were constructed in softest grounds in Japan, i.e. in lowland areas of the Kanto Plain, such as along the Naka River, in the downtown of Tokyo or in river valleys.

- In these areas, pumping of underground water caused serious settlement of the ground and the act has been restricted since the 1970's. However, slow settlement still continues.

- Because there have been no large-scale construction projects near the tunnels, the loads acting from the ground surface on the tunnels have not changed or have changed only slightly.

- The tunnels were constructed in the 1960's or 1970's using the shield tunneling method.

- The segments have not suffered notable deterioration of the materials. The configuration of the cross sections of the tunnels have deformed from a perfect circle to an oblong oval. The deformation and other abnormalities have progressed slowly in a dozen or so years. Axial cracks have developed on top of the tunnels probably due to the deformation of the sections.

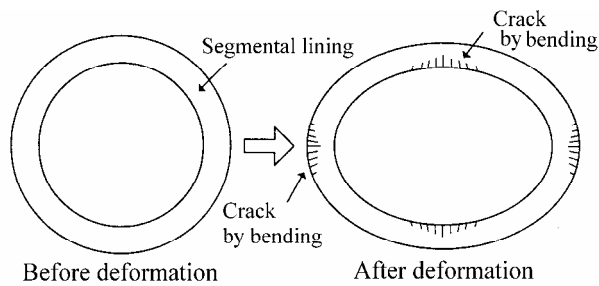

Figure 5 Deformation of tunnel

The characteristics of the deformation of a shield tunnel constructed in the soft ground in lowland area along the Naka River in the Kanto Plain are described below:

-The shield tunnel is composed of reinforced concrete segments. The tunnel was completed in 1981 and has served as an underground tunnel for accommodating power cables.

-The tunnel passes through a silt layer (Ac1) between the upper alluvial sand layers (As1 and As2) and the lower sand layer (As3). The silt is very soft and cohesive, into which gauges for standard penetration tests subsided by their own weight. The tunnel is 8 to 12 m from the ground surface in the section where deformation was found.

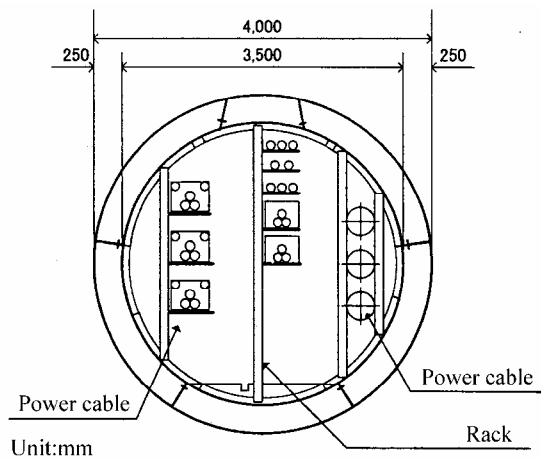

Figure 6 Cross section of the tunnel

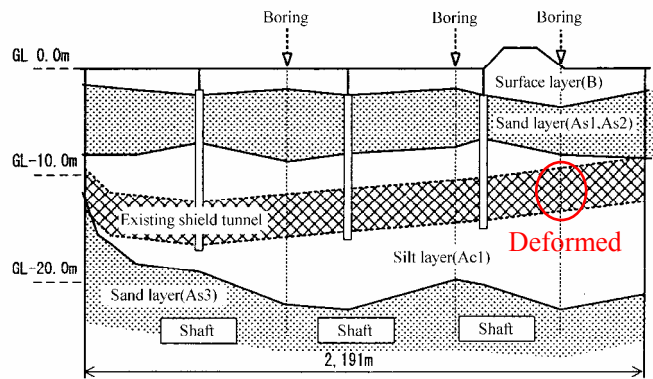

Figure 7 Profile of the tunnel

-Although the correct amount of deformation is not known because the displacement inside the tunnel was not measured at the time of completion, the vertical axis of the tunnel was flattened by about 20 mm from a perfect circle.

-As shown in Figure 8, there were steel members for supporting cables at the center of the cross section. The steel members were connected to the ceiling of the tunnel with bolts. The bolts broke due to the deformation of the tunnel, and the steel members were displaced horizontally by about 50 mm the largest.

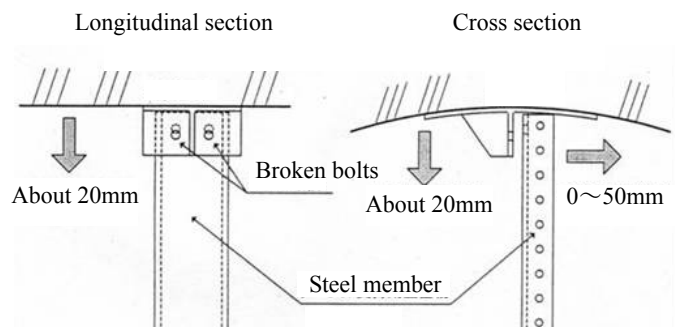

Figure 8 Deformation of the top of the tunnel

-Cracks developed on the segments are shown in Figure 9. There were almost no cracks on the sides of the tunnel. The majority of the cracks on the top of the tunnel ran along the axis of the tunnel. They were likely to be attributable to the deformation of the tunnel shown in the figure causing bending stress that acted on the cross section of the tunnel.



Figure 9 Cracks on the segments

-There were puddles inside the tunnel near the deformed tunnel section due to inflow of groundwater from joints of the segments.



Figure 10 Inflow of groundwater into the tunnel

6. STUDY OF REINFORCEMENT METHOD FOR TUNNEL DEFORMATION IN SOFT COHESIVE SOIL GROUND

Because there were no short-term changes in load acting on the tunnel and there was no prominent deterioration of the segment materials, it was likely that the load conditions near the tunnel have undergone long-term changes from those at the time of construction. The changes in load were estimated to be attributable to the changes in underground water level, such as the fall of underground water level by pumping over a large area and the inflow of groundwater into the tunnel, causing consolidation settlement of the cohesive soil layer and resultant generation of additional load.

In this paper, these changes in load are called additional long-term load.

6.1 Predicting changes in additional long-term load

To verify the generation of additional long-term load and understand its effects on the tunnel, a model experiment was conducted. A model experiment was used for the investigation because in-situ measurements and numerical analysis were difficult due to difficulties of determining analytical conditions.

The experiment was decided to be a centrifugal model experiment, with which a slow consolidation event can be observed in a short period of time. The experiment involved modeling the tunnel and the peripheral ground. Two draining conditions were reproduced in the model: 1) the fall of underground water level caused by pumping in a large area, and 2) the inflow of groundwater into the tunnel.

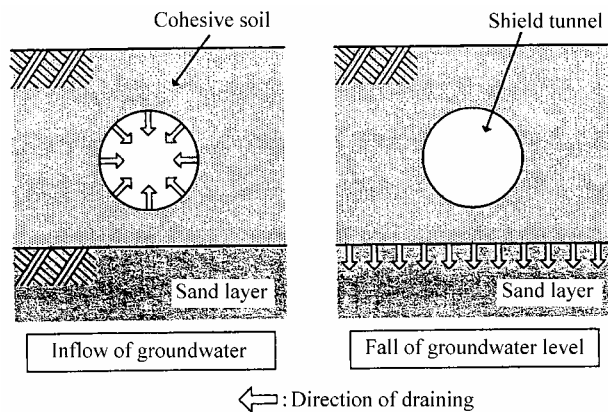

Figure 11 drain conditions

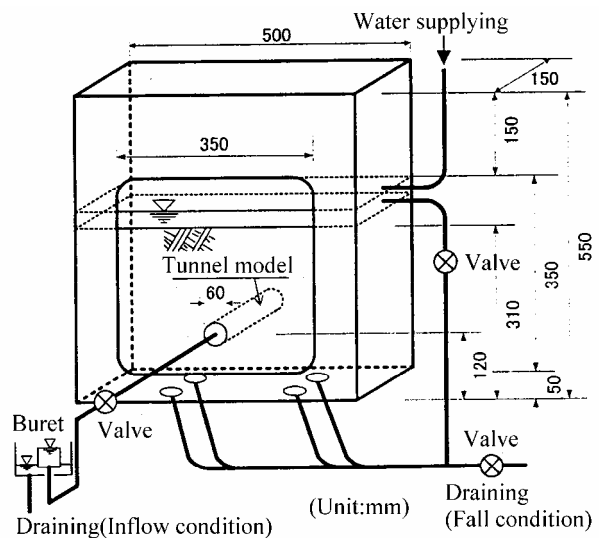

Figure 12 Overview of the experimental model

The soil pressure, water pressure, displacement of the ground, etc. were measured from the start to the end of a consolidation event caused by draining.

The results of the model experiments were analyzed by elasto-plastic coupled finite element method which can reproduce the behaviors of soft cohesive soil ground accompanying falls of underground water level. The analysis used the DACSAR program.

The comparison between experiment results and analysis results about the change rate of soil pressure acting on the tunnel model is shown in Figure 13. It is proved that the analysis method can simulate the experiment results.

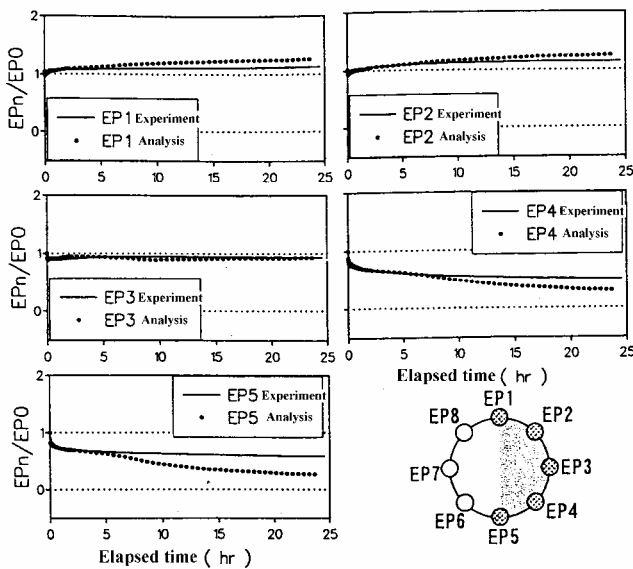

Figure 13 Change rate of soil pressure (EPn/EP0) in condition of inflow of groundwater

From the results of the model experiment and simulation analysis, the generation mechanisms of additional long-term load were found to involve the following phenomena:

- Falls in underground water level and inflow of groundwater into the tunnel caused the cohesive soil ground to consolidate and the load acting on the top of the tunnel to increase.

- The inflow of groundwater into the tunnel caused the water pressure acting on the sides of the tunnel to

drop and thus the load from the sides of the tunnel to decrease.

The changes in load can explain the deformation of the tunnel into an oblong oval.

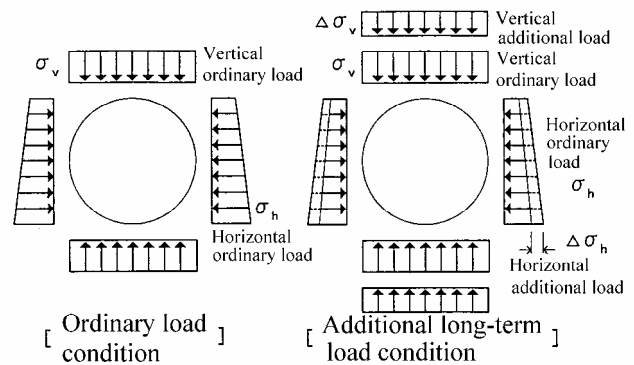

Figure 14 Change of loads acting on the tunnel

The details of the model experiment and simulation analysis are described in reference No.2 and No.3.

6.2 Reinforcement method and investigating the time of reinforcing

The reinforcement method was decided to involve installing steel reinforcements at the center of the cross section of the tunnel to prevent the additional long-term load from causing further deformation of the tunnel.

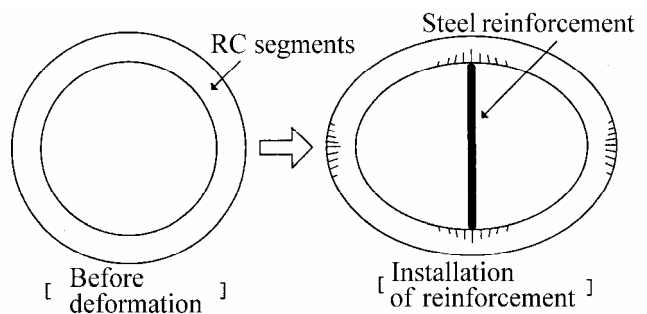

Figure 15 Reinforcement method

In this study, almost no deterioration of the tunnel structure was observed. Thus, reinforcement against changes in soil pressure acting on the tunnel was investigated. Therefore, the relationship between reinforcement and the performance of the structure in maintenance of the tunnel structure is possible to be the plot shown in Figure 16.

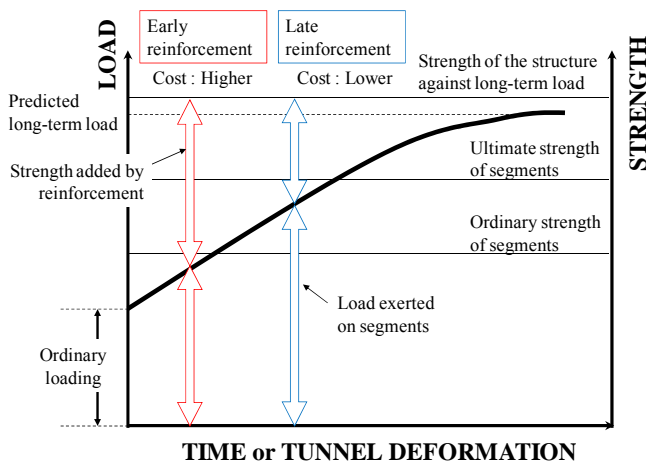

Figure 16 Approach for determining the time of reinforcement against additional long-term load

The first Y axis was put to be the load, the second Y axis was the strength of the tunnel, and the X axis was put to be time or tunnel deformation. The ordinary strength of the segments was initially designed to be safe against the ordinary load. When additional long-term load is predicted to exceed the ultimate strength of the segments, the tunnel must be reinforced at a certain time point and designed so that the strength of the entire tunnel is larger than the predicted load.

When a tunnel is reinforced by installing steel reinforcements as shown in Figure 15, installation at an early time point would result in smaller load exerted on the segments than when they are installed late but the burden on the reinforcements are higher and thus the reinforcement cost would be higher. On the other hand, late installation would reduce the burden on the steel reinforcements, but the segments would receive loads exceeding the ordinary strength and thus a heavy burden. The scale and time of reinforcement against additional long-term load should be decided by considering the balance between the reinforcement cost and the burden on segments.

6.3 Design method against additional long-term load

Today, the main stream of designing the lining of shield tunnels involves the use of the allowable stress design method. However, additional long-term load is so large that it exceeds the total overburden, and the allowable stress design method, which assumes linear calculation, is inappropriate for rational design. Therefore, the limit state design method, which uses non-linear calculations, was decided to be used.

The structure of the tunnel was analyzed using the non-linear beam-spring model. The method can precisely assess sectional force and the generation of deformation and cracks by modeling each segment, joint, and reinforcement.

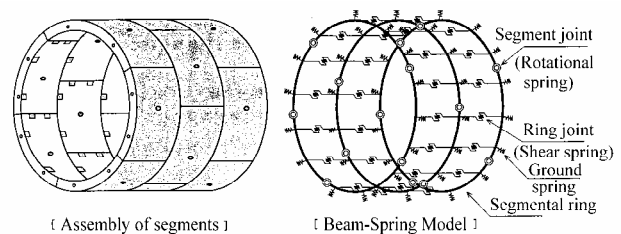

Figure 17 Model for structural analysis

The structural analysis for calculating the sectional force and deformation of the tunnel involved conducting step analyses for every small increments of load from the initial state until the additional long-term load acted.

The strength was checked using the calculated sectional forces of the segments and steel reinforcements. For example, the safety of the structure is checked on the ultimate strength of segments; and when the safety is found insufficient, the conditions are reset so as to reproduce installation of steel reinforcements, and the safety is checked again.

7. FIELD APPLICATION

The reinforcement method was applied to the tunnel in lowland along the Naka River.

From the result of the simulation analysis, the additional long-term load increased the vertical load to about 1.3 folds the largest and reduced the horizontal load to about 0.8 folds of those at ordinary loading.

From the result of the design of the reinforcement against additional long-term load, the scale of the reinforcement was decided to install steel pipes of #76.3 mm at 1.8-m intervals. The time of reinforcing the tunnel was decided to be when the displacement from the start of monitoring reaches about 5 mm.

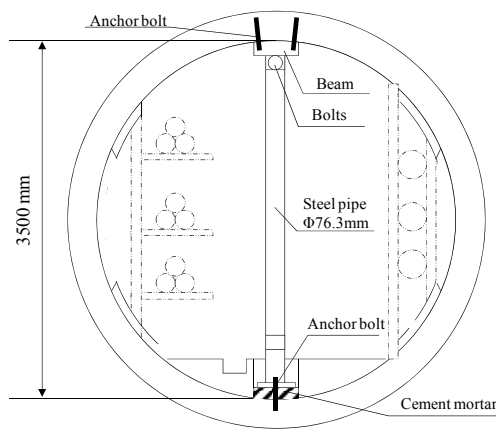

Figure 18 Reinforcement method

Because this tunnel was a highly important underground power transmission facility, the deformation of the tunnel was decided to be continuously monitored. Gauges were installed at 30 points in an about 2-km section of the tunnel. Convergence was measured at 30-minute intervals. A monitoring system was constructed with which the measurements are sent to the maintenance office in real time.

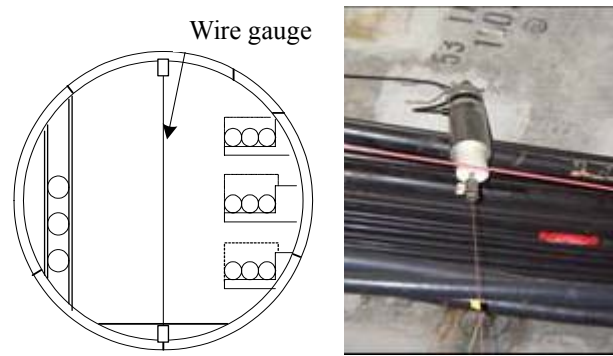

Figure 19 Monitoring convergence of the tunnel

8. STANDARDIZATION

The procedure of the design of the reinforcement against additional long-term load was standardized as shown in Figure 20.

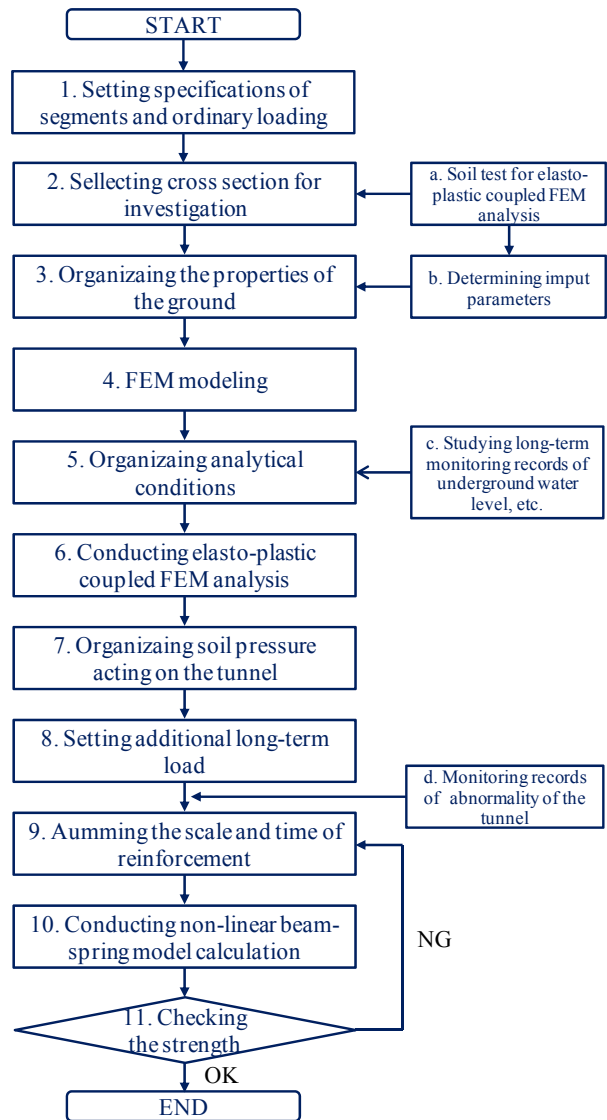

Figure 20 Procedure of design of reinforcement

9. CONCLUSIONS

The results of this study are summarized below:

1) Tunnel deformation events caused by additional long-term load were elucidated by model experiments, numerical analyses and displacement measurements.

2) A rational reinforcement design method against additional long-term load was established, which uses the limit state design method and the automatic monitoring system.

The procedure of the design of the reinforcement will be reflected in the maintenance manual and will be used for investigating reinforcement of other tunnels.

REFERENCES

1. Japan Society of Civil Engineers, STANDARDS SPECIFICATIONS FOR TUNNELING-2006 : Shield Tunnels.
2. T.Ariizumi, H.Igarashi, S.Kaneko, H.Nagatani and T.Yamazaki and O.Kusakabe, Variation of the load acting on established shield tunnel lining induced by settlement due to consolidation of ground, Journal of the Japan Society of Civil Engineers, No.750/III-65, pp.115-108, 2003. (in Japanese)
3. T.Ariizumi, S.Kaneko, Y.Enya, T.Yamazaki and O.Kusakabe, An analytical study of the long-term load acting on shield tunnel in a consolidating soft clay, Journal of the Japan Society of Civil Engineers, No.799/III-72, pp.89-108, 2005. (in Japanese)